

HI-PE Plus

ENHANCED WALK-THROUGH MULTI-ZONE METAL DETECTOR

- Accurate Detection of magnetic, non-magnetic and mixed-alloy metal weapons
- 60 localization zones:
 - 20 vertical
 - 3 lateral
- High Discrimination and Throughput
- Compliant with and Certified to the Strictest Security Standards for weapons detection
- Exceptional Immunity to external interferences
- Unmatched Reliability
- Rapid Installation

Applications

- ✓ Government Buildings
- ✓ Industries [Security]
- ✓ Nuclear Facilities [Security]
- ✓ Prisons [visitors]
- ✓ Public Events
- ✓ Amusement Parks
- ✓ Courts
- ✓ Cruise ships
- ✓ Data Processing Centers [EDP]
- ✓ Hotels
- ✓ Schools Security



HI-PE Plus Enhanced Multi-Zone Metal Detector

The new HI-PE Plus Multi-Zone Metal Detector, a development of the well-established HI-PE model. Accurate detection of all metals, high level of discrimination, full compliance with the latest Security Standards and exceptional immunity to external interferences are among the main peculiarities of this new device.

Features



- Capability to detect the full range of metal weapon threats even within body cavities
- Met-Identity technology for Identification of Threat Composition



The most advanced Security Standards require detection of all ferrous and non-ferrous metal weapons and of those constructed in special non-magnetic alloys. The HI-PE Plus detects firearms and knives of this type, even when they are hidden within body cavities, and accurately indicate the position of the threat, its intensity and its prevalent composition. Inspection personnel thereby acquire thorough knowledge of the metal item and can act, according to procedures, with maximum effectiveness and security.



- 60 pinpointing zones with high resolution & precision:
 - 20 Vertical
 - 3 Lateral



MET-IDENTITY TECHNOLOGY
 Plus allows you to know where, how much and what type of metal is being brought into the secure area.



60 LOCALIZATION ZONES
 with left, center and right indication

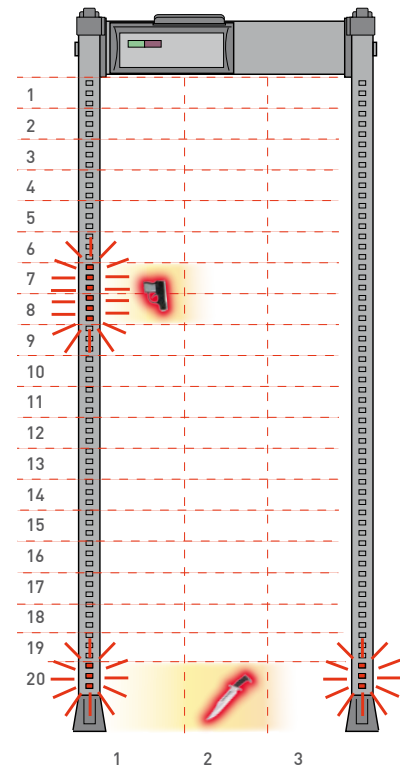

Benefits



- Cutting-edge discrimination technology allows personal effects to be ignored, creating rapid transit flow
The transit volume magnetic scanning system, invented by CEIA and applied since production of the first zonal Metal Detectors in 1986, allows state-of-the-art detection and discrimination results.

The HI-PE Plus has a very low nuisance alarm rate even at the strictest Security Levels requested today, and therefore allows high transit flow rates and the minimum need for intervention by inspection personnel.



Unique Alarm Signaling



- 4 Multi-Zone Display Bars, each programmable as entry Stop/Go and/or local alarm indication
- High visibility of the control unit and the zone indication independent from the operator position and the installation environment

Accurate signaling is essential for best operation and flow management. The HI-PE Plus provides the user with fully-programmable signaling. Both entry-points can indicate with a high level of accuracy, even simultaneously, the vertical and lateral areas of transit of the threats detected, and can also be configured as 'traffic lights' to control transits through the detector.



- Flexible Acoustic Alarm Signaling System:
 - ✓ 10 Continuous and Pulsed Tones
 - ✓ 34 Special Sounds
- 10 Acoustic Intensity Levels

A complete acoustic alarm system allows personalization of the alarm tones and intensities, with a wide choice of continuous, pulsed and special tones at different levels of intensity. The wide volume control dynamic allows operation even in very noisy environments.



- High Precision Transit Counter:
 - ✓ In-Bound Transits
 - ✓ Out-Bound Transits
 - ✓ Alarm Rate
 - ✓ Automatic Compensation for repeated transits of the same person

The Metal Detector provides an automatic count of the people passing through the access point in both directions and the related nuisance alarm percentage.



4 MULTI-ZONE DISPLAY BARS

Light bars indicate metal position vertically and laterally and can also show pacing lights.



HIGH PRECISION TRANSIT COUNTER

Two photocells fitted into the archway allow counting of transits, alarms and percentage of alarms.

Most Powerful and Versatile Security Features



Up to 50 built-in Security Programs

- ✓ Up to 30 International Standards
- ✓ Up to 20 Customizable Levels

Setting the Security Levels could not be easier and more versatile than in the HI-PE Plus. Users can choose directly from the known International Standards or request implementation of a Standard personalized to their own requirements. Users can also create their own work program and save it in internal memory provided for the purpose.



Chip Card system for fast, simple and secure parameter changes [i.e. alarm volume and tone, counter reading, etc...] and security level selection

One unique characteristic of the this Metal Detectors is the chip-card system, which allows the Head of Security to set the Security Level quickly, reliably and without having to program the device in any way.



Any security standard can be enhanced with selectable random alarm probability



CHIP CARD SYSTEM

Chip Card for automatic selection of Security Levels and parameter changes.

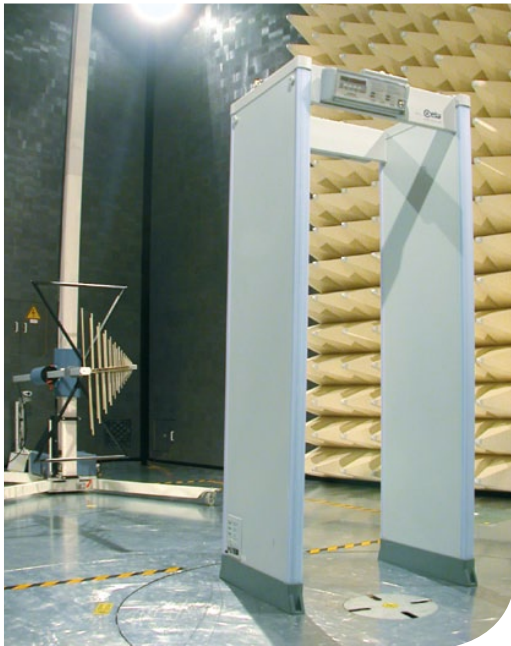

Rapid Installation



One touch guided automatic installation (OTS)

Innovative function assisting the installation through an automatic step-by-step procedure



Continuous self diagnostics assures monitored performance reliability

Communication Capabilities



Exceptional immunity to environmental interferences makes the Metal Detector easy to use even when electrical noise is encountered.

TYPE OF OPERATION	Ethernet	USB	Infrared	Bluetooth	RS-232
Maintenance	○	○		■	■
Remote Control	○		■	■	■
Remote Data collection	○				

■ STANDARD ○ OPTION

Model Configuration



Features	HI-PE Plus/PZ
Compliant with the strictest detection and discrimination standards for EMDs (Enhanced Metal Detectors)	■
4 display bars each programmable as zone indicators and/or pacing lights	■
60 localization zones (20 vertical x 3 lateral) with left, center and right indication	■
Chip Card Reader	■
Bluetooth, infrared and RS-232 communication	■
High precision transit counter	■
Programmable Random Alarm capability	■
3-Level Password and hardware key access protection	■
Met-Identity technology (separate Ferrous and Non-Ferrous alarm signaling)	■
One Touch Automatic Self Installation (OTS)	■
Automatic Operational Functional Verification (OFV)	■
Automatic Vibration Compensation (AVS, EVA)	■
Automatic Channel Search (CS)	■
Automatic Floor Gain Adjustment (FGA)	■
Automatic Technical Functional Verification (TFV)	■
Automatic Environmental Noise Compensation (ENA)	■
Powered by safe low voltage DC	■
Anti-tamper on/off switch	■
Integrated web-server & logger (includes Ethernet and USB interface)	○
Weather resistant protection	○
Anti-vandalism, anti-tampering protection	○
IP65 protection (includes weather resistant and anti-vandalism options)	○
Embedded battery charger and under-voltage protection	○
Long life crossbar battery back-up	○
32.3" useful passage width	○

■ STANDARD ○ OPTION

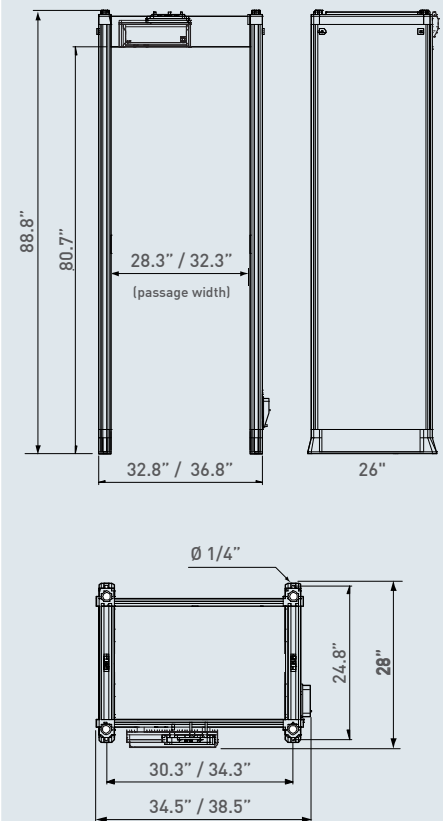
Dimensions



UNDER THE ALARM THRESHOLD

-  Small metal mass
-  Medium metal mass

OVER THE ALARM THRESHOLD

-  Medium metal mass
-  Large metal mass

 Green and Red Metering Signals Proportional to the Metal Mass Detected

HI-PE Plus
Enhanced Multi-Zone Metal Detector

Options / Upgrade Kits

➤ **Weather Resistant Protection**

Kit for upgrading the standard version to outdoor applications according to IEC 60950-22; this kit includes shelters, crossbars, protection covers for power supply and IP67 mains power supply adapter.

- 28.3" passage width (part # 55630)
- 32.3" passage width (part # 55633)



➤ **Anti-vandalism, Anti-tampering Protection**

This option includes stainless steel control unit, IP67 mains power supply adapter, protection covers for power supply and antenna connection compartments, equipped with screws requiring tools for removal. Part # 55629



➤ **IP65 Protection**

This option includes the Weather Resistant and Anti-vandalism kits.

- 28.3" passage width (part # 55631);
- 32.3" passage width (part # 55632)

➤ **32.3" Useful Passage Width**

Part # 55635

➤ **Long life crossbar battery back-up**

Crossbar battery back-up in stainless steel case. Provides up to 8 hours of autonomous working time.

Part # 55681



➤ **Embedded Battery Charger and Under-voltage Protection**

Anti-tamper on/off switch, RS-232 interface, battery charger with 12 hours mains disconnection diagnostic alarm.

Part # APSM2Plus/P



➤ **Integrated Web-server & Logger, Battery Back-up and Charger**

Anti-tamper on/off switch, RS-232, USB, 10/100 baseT Ethernet interface, data logger, real-time clock, integrated web-server, transit statistical data analysis, 20' internal battery back-up with 12 hours mains disconnection diagnostic alarm.

Part # APSiM2Plus/P



Accessories

➤ Chip Cards

Chip cards for simple and secure selection of Security Levels and parameter setting. List of chip-cards available on request.



➤ RCU2

Control unit for full remote access, including alarm signaling and programming of CEIA Walk Through Metal Detectors (part # RCU2). The connection is performed via bluetooth (standard) or via cable connection (part # 3618).



VISUAL ALARM WITH ZONE INDICATION



➤ MBSU-2

Independent, compact size, long life power supply in weatherproof stainless steel case, with embedded fast charger:

- 14 hours typical (10 hours minimum) continuous operation with HI-PE Plus
- 5 hours typical charging time.

Part # MBSU-2

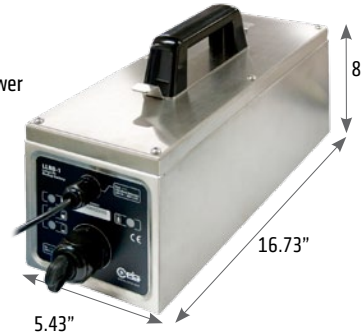

➤ MD-Scope2

Powerful, PC based installation and service software. Includes oscilloscope and terminal functionality (part # MD-SCOPE2).

The connection is performed via bluetooth (standard) or via cable connection (part # 3805).



➤ IRC-1

Infrared Remote Controller for wireless remote programming of the control unit.

Part # 47180



➤ Metal Detector Divesting Table FOR MANAGEMENT OF PERSONAL METAL BELONGINGS

- Standard length: 24" (Part # 18074)
- Extended length: 47" (Part # 39491)



➤ Upper Connection Module

This extension cable allows the connection of power supply and serial communication to personal computers or CEIA accessories, such as RCU-2. Part # 46650

➤ RRU

Remote relay unit (RRU) to repeat the detection alarms of the gate through a relay contact. The RRU module can be used for integration of the Metal Detector in interlocked door systems. Part # RRU

➤ IP67 Mains Power Supply

100W IP67 power supply for heavy duty applications. Vandal resistant.

It is provided with flanges for simple installation.

Part # 62697



➤ Stainless Steel Deck Dolly

FOR LOCAL MOVING OF THE PANEL METAL DETECTOR GATE

- Robust construction in AISI 316L stainless steel
- Rubber-covered castor-type wheels for easy movement
- Incorporated handles for transport (available only for 28.3" useful passage width: part # 50789)



➤ Test Samples Kit

Reference Samples for accurate verification of the Security Level. Includes guided procedures and certificate of calibration.

- Part # EMD-SK-GAL
- Part # EMD-SK-GDML



➤ ID-Holder

This accessory is designed to be hung on a crossbar of the archway, either at the entrance or the exit side. It can hold, for instance, a notice or an ID number for waiting people or for the screener.

Part # 54095



HI-PE Plus Enhanced Multi-Zone Metal Detector

Specifications

KEY FEATURES	Wide range of threat detection from guns to ½ cutter blade	Automatic Environmental Noise Compensation (ENA)
	Excellent discrimination of personal metal effects	Met-Identity technology identifies and signals the metal type in real time
	60 localization zones (20 vertical x 3 lateral) with left, center and right indication	High precision bidirectional counter with automatic rescreening compensation
	One touch automatic self installation (OTS)	Chip Card capability for fast, simple, and secure programming
	Automatic Operational Functional Verification (OFV)	Random alarm capability programmable from 0% to 100%
	Automatic Vibration Compensation (AVS,EVA)	Exceptional Immunity to external interferences
	Automatic Channel Search (CS)	Powered by safe low voltage DC
	Automatic Floor Gain Adjustment (FGA)	Standard Interfaces: RS-232, Bluetooth, Infrared
	Automatic Technical Functional Verification (TFV)	Other available interfaces: Wi-Fi, Ethernet, USB
QUALITY	Continuous self diagnostic system	
	Proven reliability	
	No periodic re-calibration and preventive maintenance required	
	No scheduled maintenance	
	Fully digital design	
WALK-THROUGH GATE STRUCTURE	State-of-the-art, robust and washable panels	
	Protected against aging, weather and wear	
CENTRAL CONTROL UNIT	Ergonomic and robust design	
	High visibility alphanumeric display and programming keyboard	
	Made of advanced plastics or stainless steel and anti-vandalism construction (option)	
	Access to the front panel protected by hardware key and 3 levels of passwords	
ALARM SIGNALING	VISUAL SIGNALS	Multi-zone display bar for "height on person" localization
		4 light bars with selectable entry/exit and pacing indication
		Green and red metering signals proportional to the mass of the detected target
	AUDIO SIGNALS	10 selectable continuous and pulsed tone plus 34 special tones
		10 selectable sound intensities ranging from 0 to 90 dbA at 1m
TYPE OF SIGNALING	VISUAL	Fixed or proportional to the mass in transit - visible from 6m under lighting of 4000lux
	VISUAL ZONE INDICATION	60 distinct zones (20 vertical x 3 lateral) entry and exit side
PROGRAMMING	Up to 50 built-in security programs (up to 30 International Standards, up to 20 Customizable Levels)	
	Remote via RS-232, Infrared Remote Control Unit, Bluetooth or Ethernet 10/100 base T (option) interface	
	SECURITY LEVEL	International Standard (IS) command
		Chip card
	Local by Control Unit alphanumeric display and keyboard	
	Programming and chip card access protected by user and super-user passwords	
OPERATIONAL FEATURES	Very high discrimination and transit flow rates five or more times greater than other metal detection systems	
	Quick reset time as short as 0.2 seconds for high throughput rate	
	Very high detection speed (up to 50 ft./sec.)	
	Built-in operational functional verification	
	One-touch key reading of inbound, outbound and Security Level Data	
INSTALLATION DATA	Automatic synchronisation between two or more metal detectors with distance of down to 2" (5 cm) without the use of external cables	
	Automatic Installation function (OTS)	

Environmental Data

- POWER SUPPLY : 100...240V~ -10/+15%, 47...63Hz, 40 VA max
- OPERATING TEMPERATURE: -4°F to 158°F (-35°F to 158°F upon request)
- STORAGE TEMPERATURE: -35°F to 158°F
- RELATIVE HUMIDITY: 0 to 95% (without condensation)

Certification and Compliance

- Compliant with and certified to the applicable Standards for Enhanced Metal Detectors
- Compliant with the applicable electromagnetic Standards on Human Exposure and Pacemaker Safety
- Compliant with all Airport Security Standards worldwide
- Compliant with applicable International Standards for electrical safety and EMC
- Harmless to magnetic media (CDs, tapes, etc.)

Comprehensive support

CEIA USA PROVIDES FULL OPERATIONAL AND TECHNICAL TRAINING SUPPORT BY CERTIFIED PERSONNEL EITHER AT CEIA USA FACILITY OR AT CUSTOMER PREMISES

- phone technical support
- in-house and on-site repair/services
- standard and custom training

